

Battery free PowerSafe UPS with Industrial-Grade Supercapacitors

## Features

- 8x/8S Industrial 370 Farads Supercapacitors
- Up to 200W Max. Power Output
- 1 x COM, 1 x USB for GUI Remote Management and Monitoring
- 2 IN / 2 OUT DIO
- -25°C to 55°C Wide Operating Temperature
- EN50155: EN50121-3-2, CE, FCC Class A
- 3x Smart Modes with Remote On/Off, Ignition Control, Delay Time
- 12V/24V Compatibility: Industrial PCs, Panel PCs, Displays

## Specifications

### Power

<b>Power Input</b>	12 ~ 35 VDC 3-pin Terminal Block (V+, GND, IGN IN)
<b>Power Output</b>	DC OUT 12/24 VDC Charge mode: DC IN Voltage bypass (DC OUT = DC IN) Discharge mode: 12V or 24V 3-pin Terminal Block (V+, GND) Max.100W output
<b>Capacity</b>	8x 370 Farads Supercapacitors
<b>Charging Mode</b>	Quick and Normal Charging
<b>Power Ignition</b>	Power Ignition Management
<b>Power Protection</b>	OVP (Over Voltage Protection) OCP (Over Current Protection) Reverse Protection

### Environment

<b>Operating Temperature</b>	-25°C to 55°C
<b>Storage Temperature</b>	-30°C to 85°C
<b>Humidity</b>	10% to 95% (non-condensing)
<b>Vibration</b>	5 Grms, 5 - 500 Hz, 0.5 hr/axis
<b>Shock</b>	20G, half sine, 11ms

### Certification Information (in Process)

<b>Certification</b>	CE, FCC Class A EMC Conformity with EN50155, EN50121-3-2
----------------------	---

### Physical

<b>Mounting</b>	Wall Mounting, DIN Rail Mounting (Optional)
<b>Chassis</b>	Heavy Duty Metal
<b>Dimensions(W x H x D) (mm)</b>	100 X 192 X 192
<b>Net Weight</b>	1.8 kg

### I/O Connector

<b>COM</b>	1 x RS-232
<b>DIO</b>	2 x DI / 2 x DO
<b>USB</b>	1 x USB Type A
<b>Others</b>	1 x Remote Power On/Off 1 x Smart Mode Switch 1 x Mode Reset Switch

## Backup Management Software Tool : MiPowerBackup

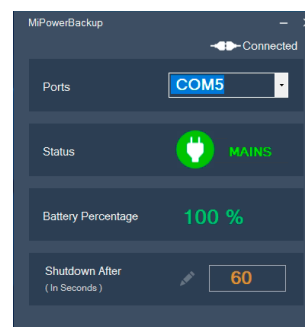
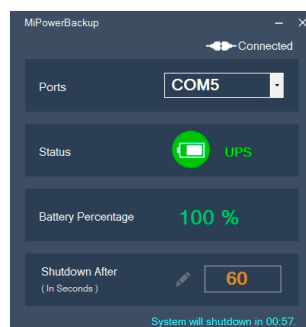
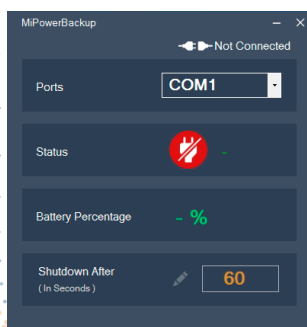

## Product Front I/O View

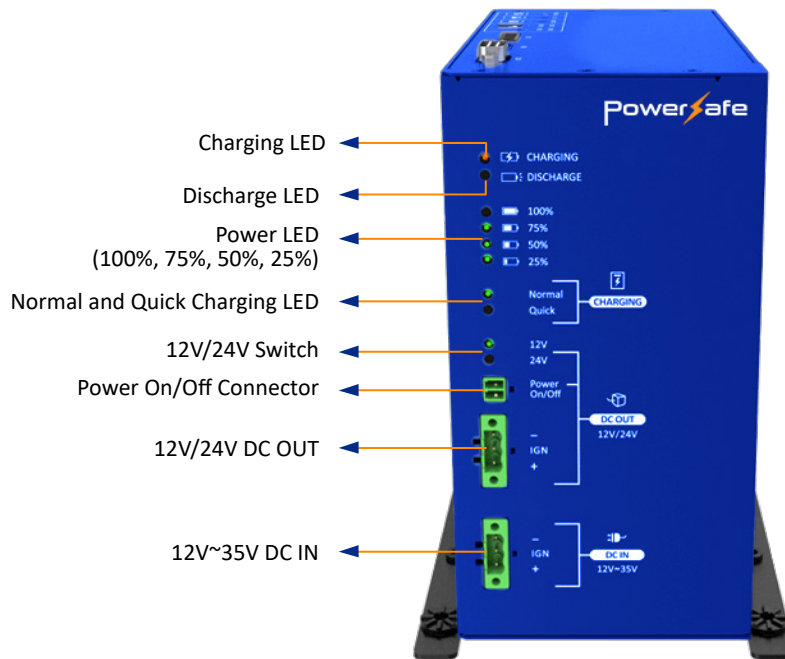

## Product Top I/O View

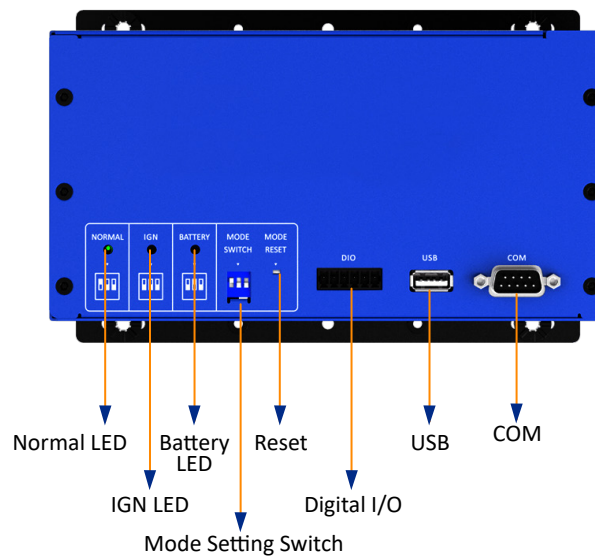

## Mechanical Drawings (Unit = mm)

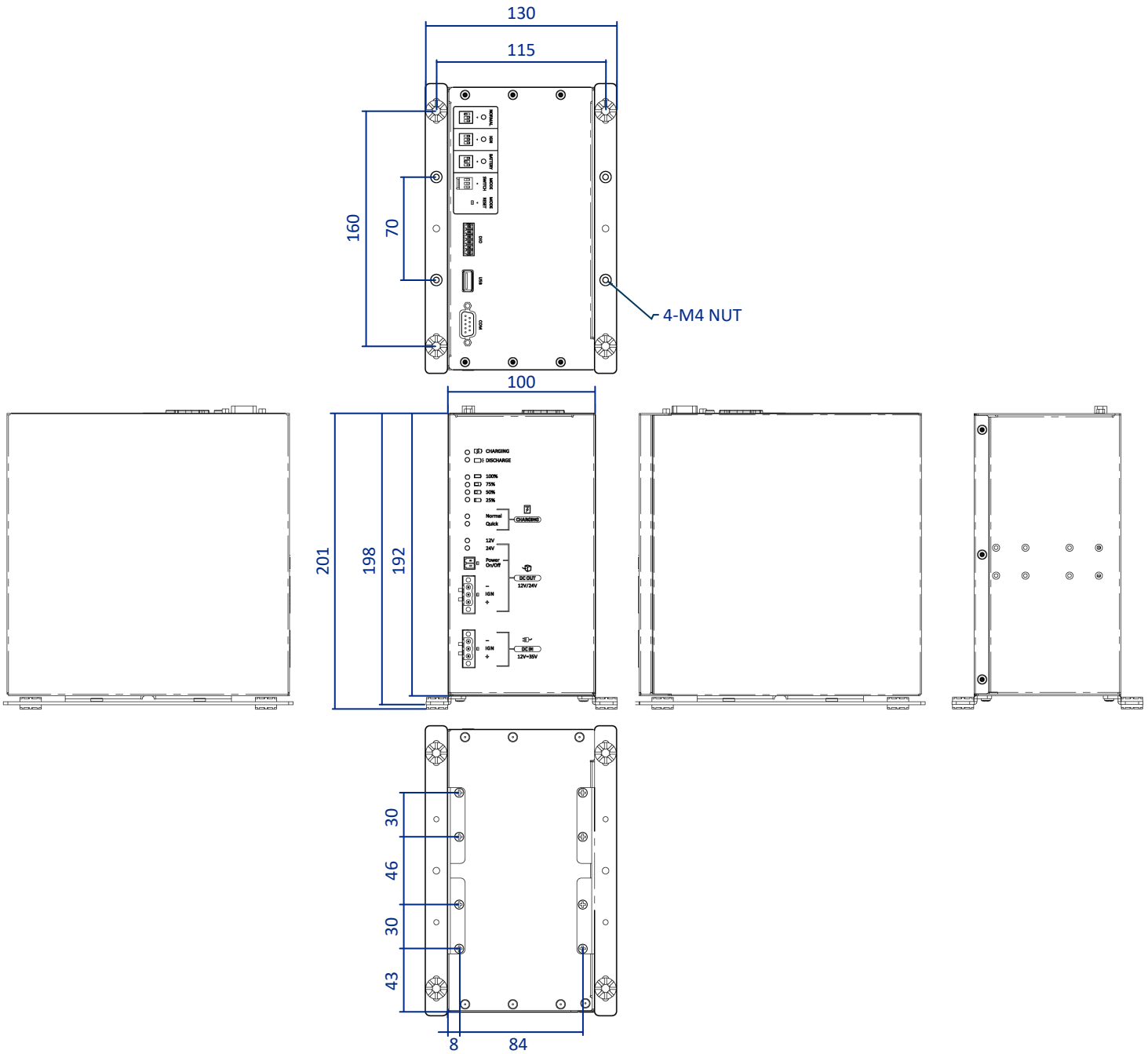

## Ordering Codes

Model Number	Description
PowerSafe SCB-100	EDGEBoost power backup system with 8S Industrial-Grade Supercapacitors, DC IN 12 ~ 35 VDC, DC OUT 12/24 VDC

PowerSafe SCB-100\_24-05-2024